



SPECIFICATION

3020 * measurements identified by an asterisk are taken in accordance with the new IHF A-202 amplifier measurement standard.

Power Amplifier Section

- * Continuous average power output at 8 ohm 20-20K Hz both channel driven Rated distortion.
- * Clipping headroom at 8 ohm
- Clipping power at 8 ohm /4 ohm /2 ohm
- Dynamic headroom at 8 ohm
- Dynamic power at 8 ohm /4 ohm /2 ohm
- * Reactive load rating
- * Transient Overload Recovery Time
- * Slew Factor
- Slew Rate
- Damping factor at 50 Hz (Ref. 8 ohm)
- T.H.D 20-20K Hz From 250mV to 20W
- S.M.P.T.E I.M.D (60 Hz + 7K Hz, 4:1) From 250mW to 20W
- I.H.F I.M.D (19K Hz + 20K Hz) at 20W
- T.I.M (15K Hz Sine + 3.18K Hz Square Wave) at 20W
- Frequency Response, 20-20K Hz (From Lab. IN)
- Frequency Response Range ± 3 dB

Preamplifier Section

- * Input Impedance Resistance/Capacitance
- Input Sensitivity (1K Hz) * For 1 Watt out/20 Watt out
- Input Overload at 20Hz/1K Hz/20K Hz
- T.H.D (20-20K Hz) and IMD at +30 dB input level
- RIAA Response Accuracy
- Signal to Noise Ratio A Weighted
- (a) With phono cartridge connected Ref 10mV/* Ref 5mV
- (b) With short-circuit input Ref 10mV

High Level Input

- * Input impedance Resistance/Capacitance
- Input Sensitivity * For 1 Watt out/For 20 Watt out
- Signal to Noise Ratio, A-Weighted * Ref 1 Watt out
- * Maximum input signal Ref 20 Watt out
- Frequency Response, 20-20K Hz

Controls

- Bass control range at 50 Hz
- Treble control range at 10K Hz
- Infrasonic filter Turn Over frequency (From Normal IN)
- Slope (dB/octave)

Power Consumption

Weight
Dimension Height x Width x Depth (mm)

>20W
<0.02%
+1.5 dB
28W/37W/42W
+2.9 dB
39W/58W/72W
+1.7 dB
<1 μ Sec
>5
15V/ μ sec
>55
<0.02%
<0.02%
<0.02%
<0.02%
 ± 0.5 dB
10-70K Hz

47K Ω /47 pF
0.5mV/2.5mV
27mV/270mV/2V
<0.02
 ± 0.3 dB

80 dB/75 dB
84 dB

20K Ω /100pF
30mV/150mV
>80 dB
>110 dB
Infinite
 ± 0.5 dB

± 10 dB
 ± 7 dB
15 Hz
12
150 VA
5.26 Kg
96x420x240

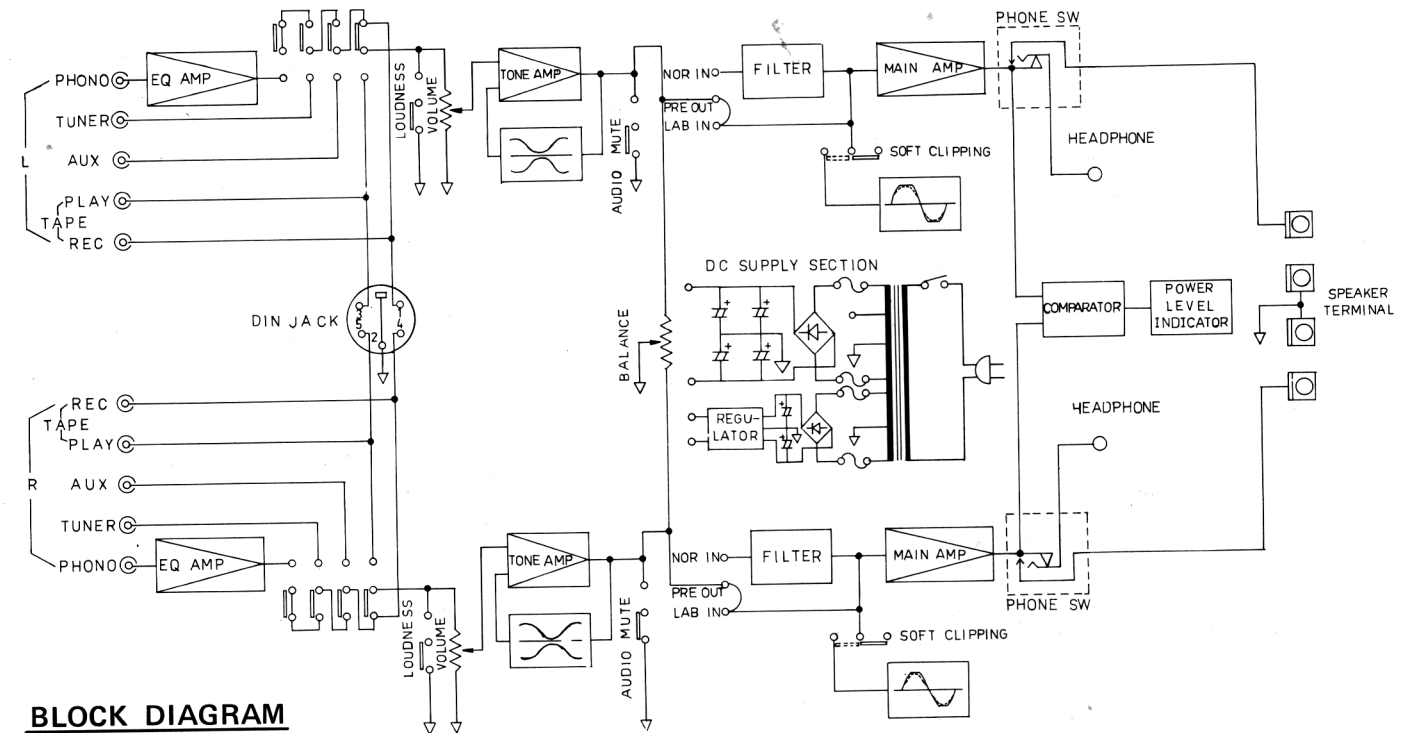

BLOCK DIAGRAM

3020

0203

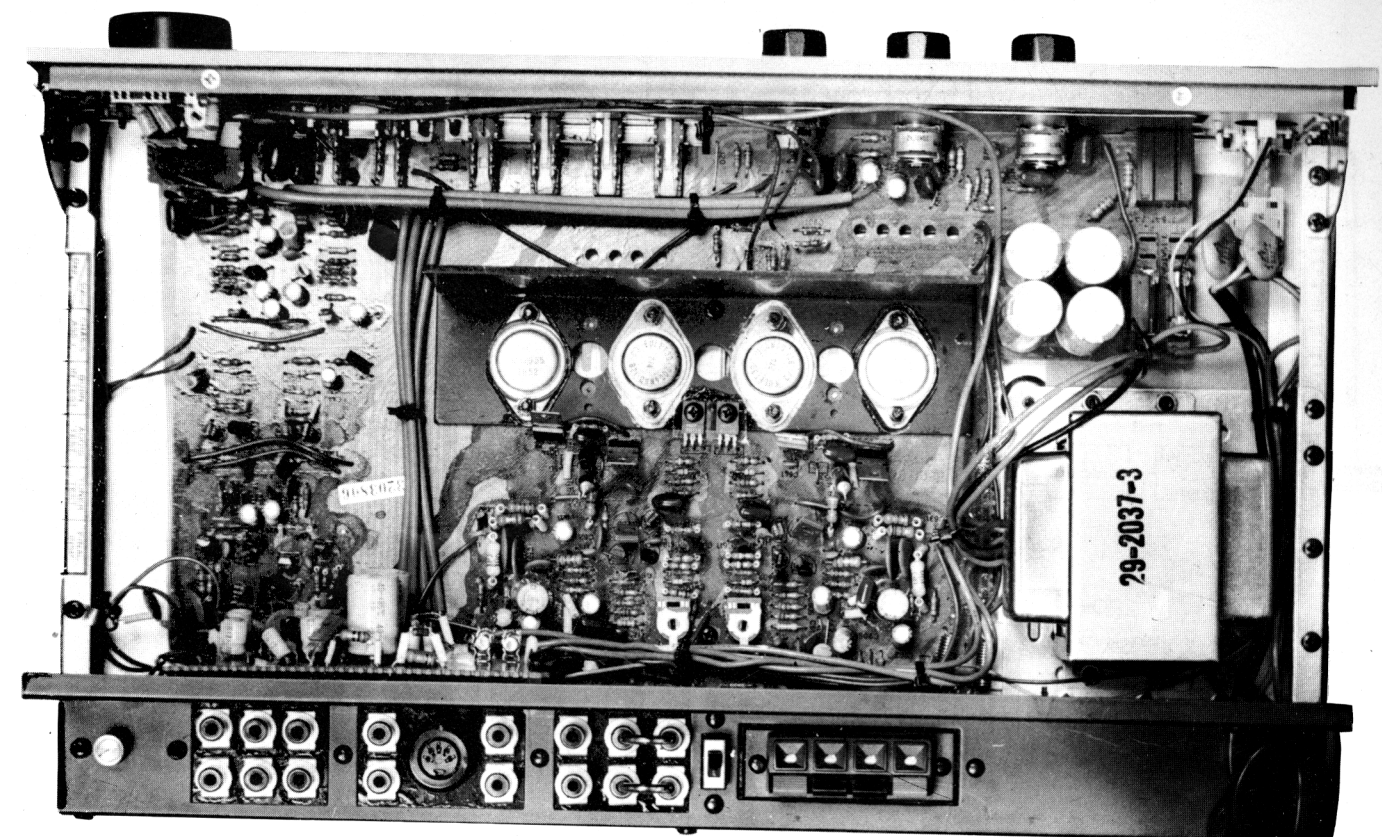

IDLE CURRENT ALIGNMENT

- 5 Minutes minimum pre-heating is necessary.
- Set the volume control at minimum position.
- Connect DC milli-voltmeter across R654 for right channel and across R653 for left channel. The meter sensitivity should be set for 30–100mV full scale deflection. RX1 (right channel) and RX2 (left channel).
- Insert 1 kohm carbon resistor to connect in parallel with R654 (right channel) and R653 (left channel).
- After insert 1Kohm. if the reading of meter were between 5 mV and 11mV then the alignment is completed.
- If the reading were less than 5mV then the value of RX1 or RX2 should be reduced till the reading is between 5mV and 11mV.
- If the reading were more than 11mV. then the value of RX1 or RX2 should be increase till the reading is between 5mV and 11mV.

DC OFF-SET ALIGNMENT

- 5 Minutes minimum pre heating is necessary.
- Set volume control at minimum position.
- Connect a DC milli-voltmeter to the speaker terminals of each channel. The meter sensitivity should be set for 100-300mV full scale deflection. The positive input of the meter should be connected to the red (+) speaker terminal.
- Adjust VR5 (for left channel) and VR6 (for right channel) till the meter reading is zero.

POWER INDICATOR ALIGNMENT

- Feed an 1KHZ sine wave approx 150 mV RMS to AUX Input.
- Connect an 8 ohm dummy load and an AC voltmeter and oscilloscope to the speaker terminals.
- Set the volume control till the output voltage is 12.6V making sure that no dipping of the waveform is occurring.
- Adjust VR7 till the LED D5 (marked 20W) is lighted.

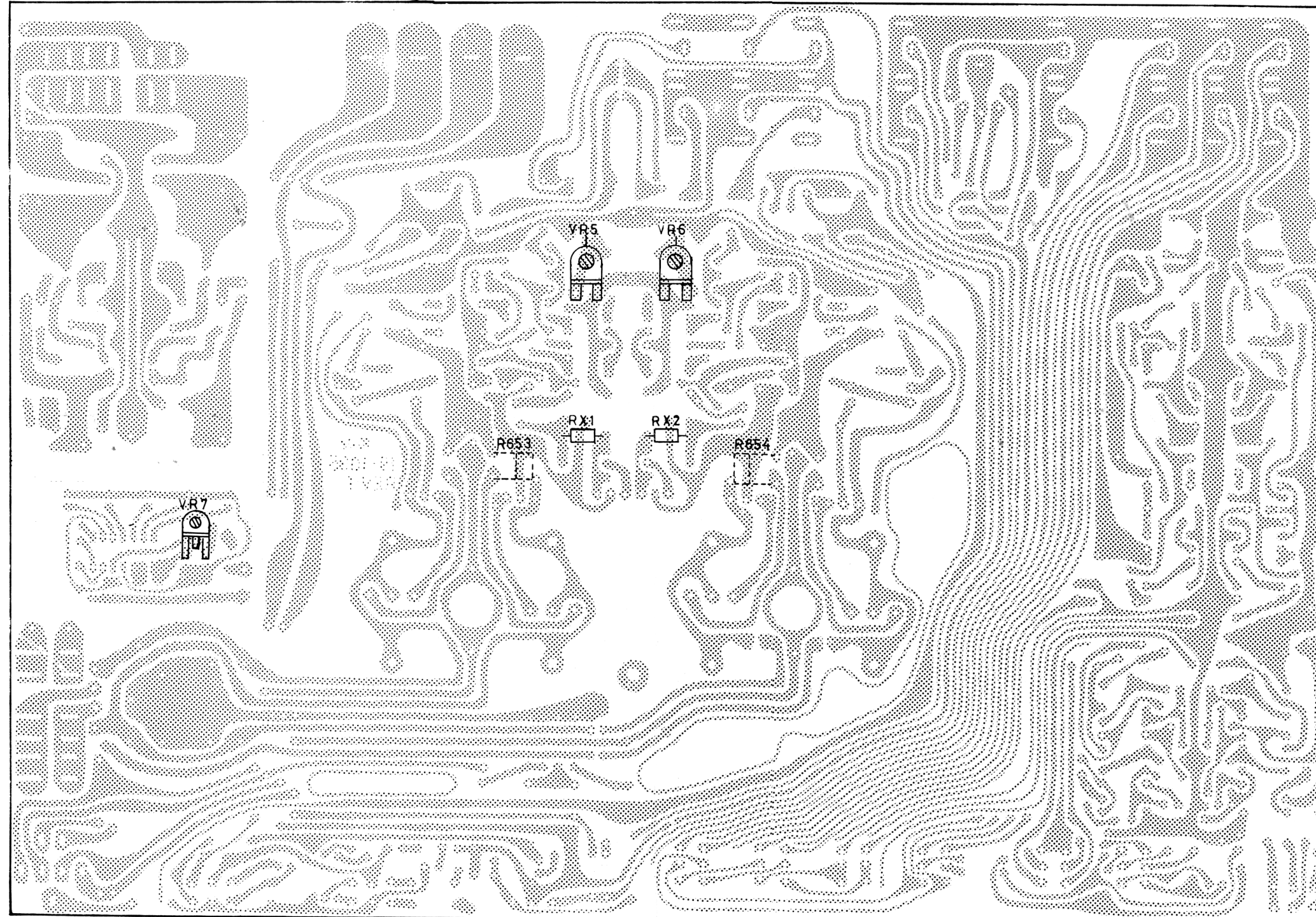

(PART SIDE VIEW)

3020 ASSEMBLY DIAGRAM

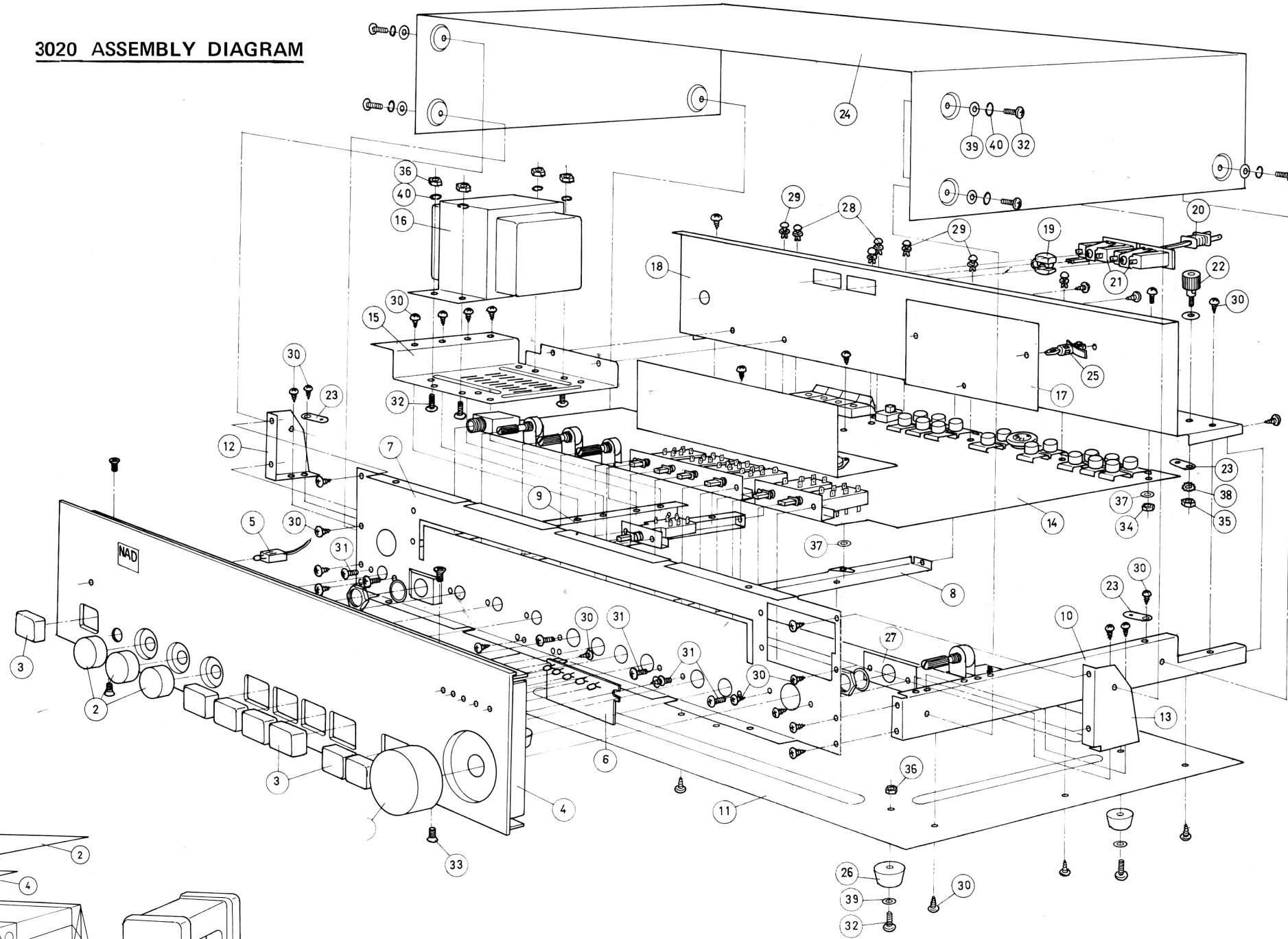

Item	Number	Name	Qty
1	12-3036	Volume Knob	1
2	12-3038	Control Knob	3
3	12-3039	Push Knob	7
4	11-8066	Front Panel	1
5	14-4003	Wire Assembly	1
6	19-1095	L.E.D. Driver	1
7	11-6046	Front Chassis	1
8	11-6044	Center Chassis	1
9	11-6040	Auxiliary Chassis (left)	1
10	11-6039	Auxiliary Chassis (right)	1
11	11-6038	Bottom Chassis	1
12	11-2113	Bracket (left)	1
13	11-2112	Bracket (right)	1
14	90-1095	P.C.B. Assembly	1
15	11-2114	Bracket for Transformer	1
16	29-2037	Power Transformer	1
17	19-1095	Regulator	1
18	11-8072	Back Panel	1
19	14-5005	Cord Bushing	1
20	14-5013	Power Cord	1
21	12-2006	A.C. Outlet	2
22	15-2037	Ground Screw	1
23	11-3026	Lug (Ground)	3
24	50-1015	Cabinet	1
25	13-7003	P.C.B. Holder	3
26	28-1011	Rubber Feet	4
27	11-2123	Bracket for Volume	1
28	15-2048	Plastic Screw 3 x 5.5	2
29	15-2047	Plastic Screw 3 x 4.5	5
30	S5B03+108SL-2	Triangle Screw 3 x 8	38
31	S1B03+106SL-2	Machine Screw 3 x 6	7
32	S1B04+110SL-2	Machine Screw 4 x 10	12
33	S1E03+108SZ-2	Flate Machine Screw 3 x 8	4
34	N03B5102SZ	Nut 3 x 5.5 x 2	1
35	N35B06128SZ	Nut 3.5 x 6 x 2.8	1
36	N04B07132SZ	Nut 4 x 7 x 3	8
37	A03A08F0.5	Fiber Washer 3 x 8 x 0.5	3
38	A35107SZ01	Gear Washer 3.5 x 7 x 1	1
39	A04A10SL01	Washer 4 x 10 x 1	12
40	A04G07SL01	Spring Washer 4 x 7 x 1	12

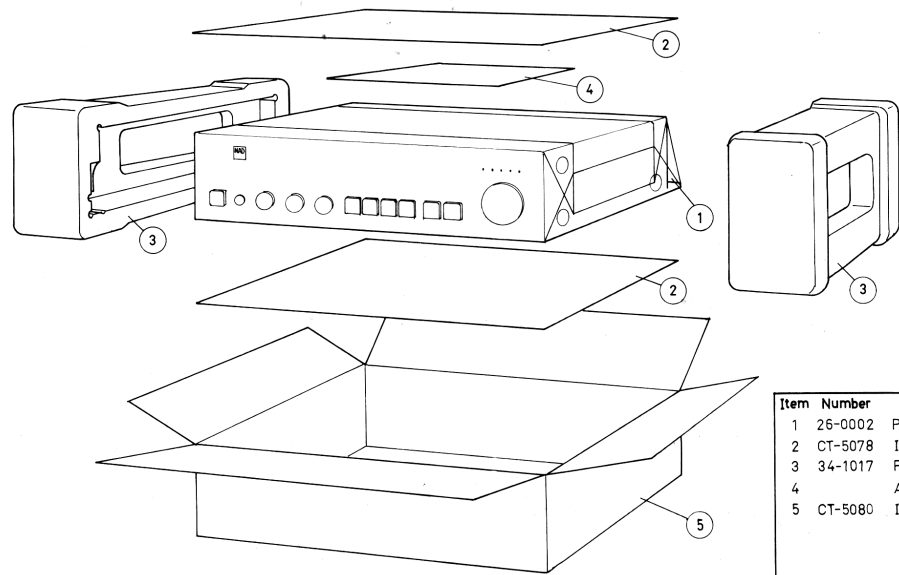

Item	Number	Name	Qty
1	26-0002	Poly Paper	1
2	CT-5078	Inner Board	2
3	34-1017	Polytone	2
4		Accessory Parts	1
5	CT-5080	Inner Carton	1

3020 PCB PARTS LOCATION/WIRING DIAGRAM

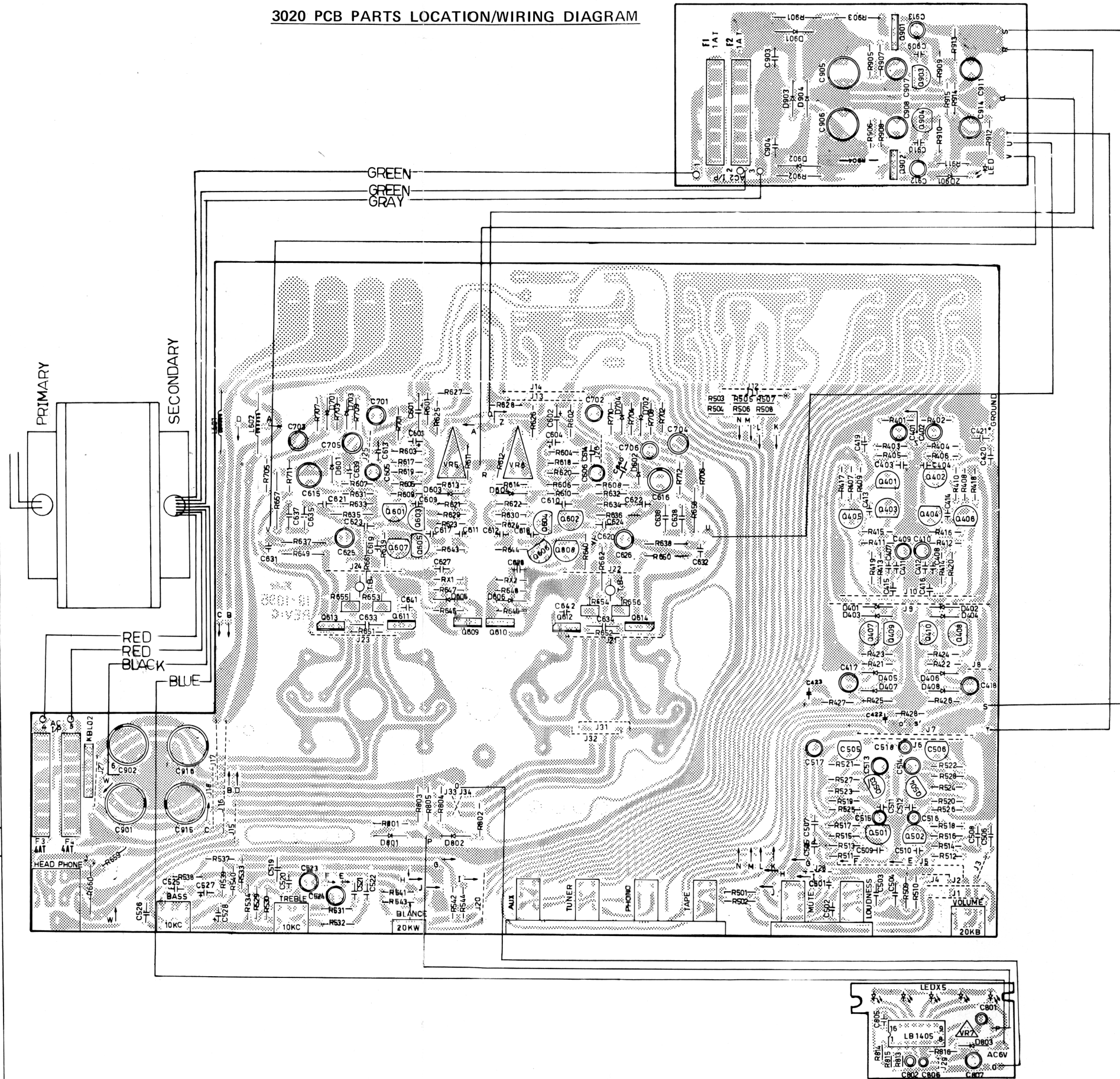
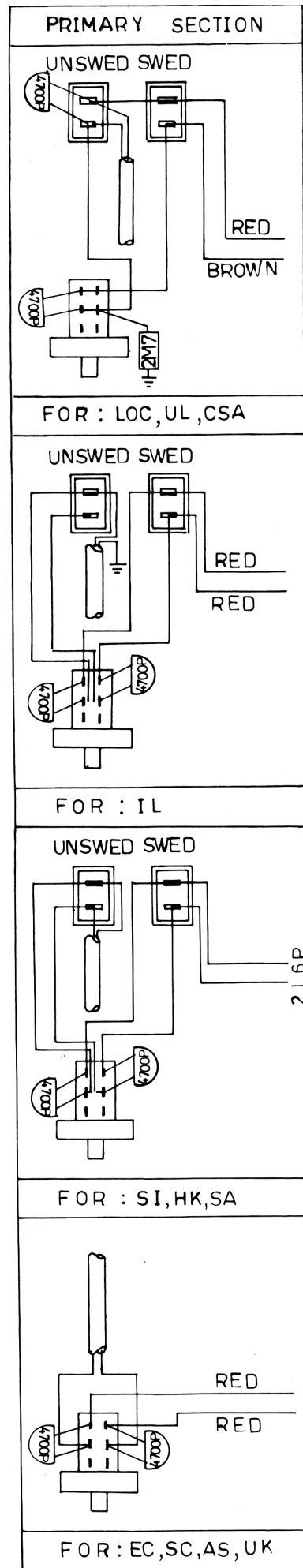

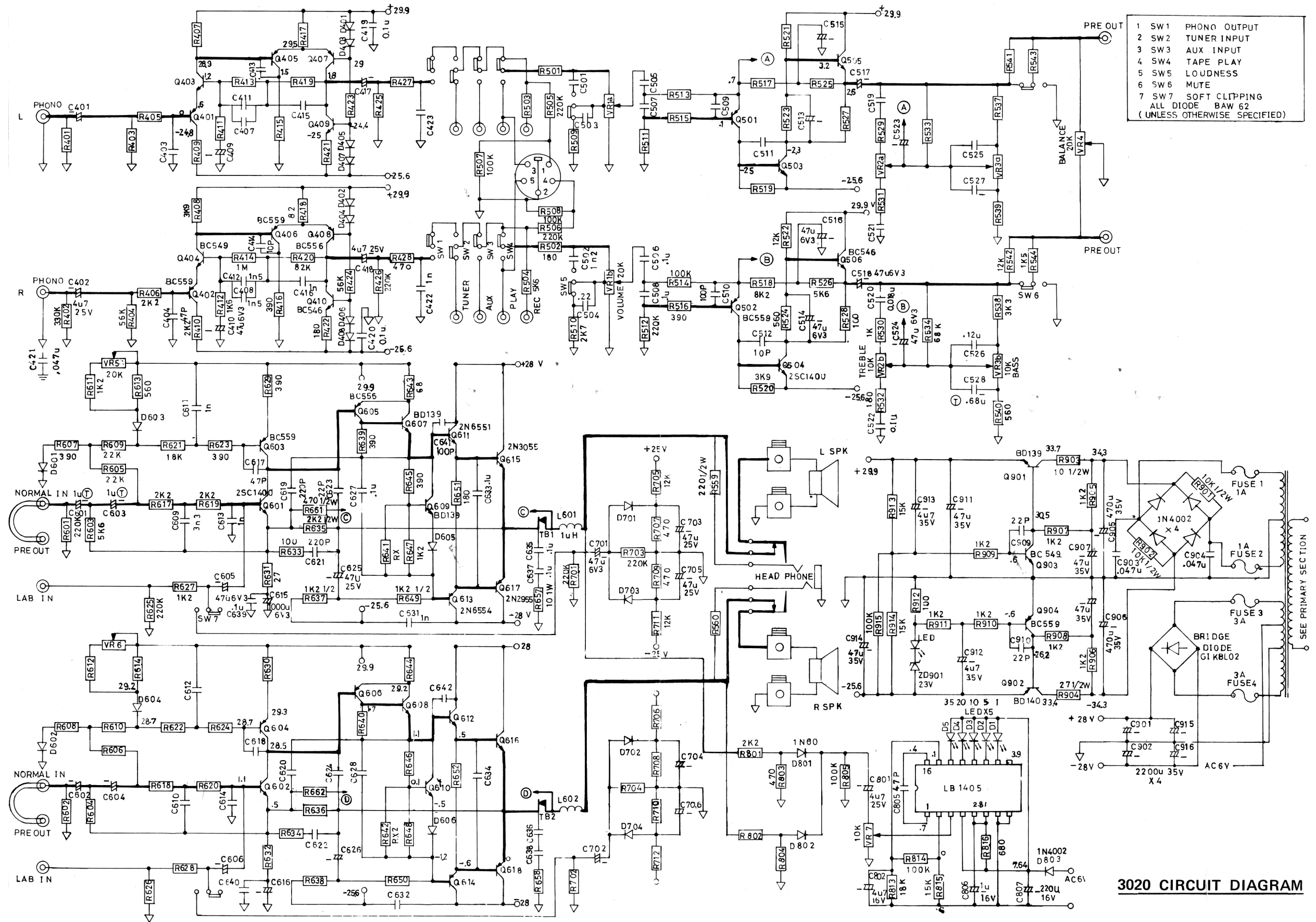

- 1 SW1 PHONO OUTPUT
 - 2 SW2 TUNER INPUT
 - 3 SW3 AUX INPUT
 - 4 SW4 TAPE PLAY
 - 5 SW5 LOUDNESS
 - 6 SW6 MUTE
 - 7 SW7 SOFT CLIPPING
- ALL DIODE BAW 62
(UNLESS OTHERWISE SPECIFIED)

3020 CIRCUIT DIAGRAM

3020 PARTS LIST

SYMBOL NO.	PART NO.	DESCRIPTION	SYMBOL NO.	PART NO.	DESCRIPTION	SYMBOL NO.	PART NO.	DESCRIPTION
R401, R402	16-¼CM334J	Carbon res 330K ±5% ¼W	R814	16-¼CU104J	Carbon res 100K ±5% ¼W	Q601, Q602	30-2124	Transistor 2SC1400
R403, R404	16-CM563J	Carbon res 56K ±5% ¼W	R815	16-¼CU153J	Carbon res 15K ±5% ¼W	Q603, Q604	30-2085-2	Transistor BC559B
R405, R406	16-¼MM222J	Metal Film res 2K2 ±5% ¼W	R816	16-¼CM681J	Carbon res 680 ±5% ¼W	Q605, Q606	30-2096	Transistor BC556
R407, R408	16-¼CN392J	Carbon res 3K9 ±5% ¼W	R901, R902	16-½CM103J	Carbon res 10K ±5% ½W	Q607-Q610	30-2083	Transistor BD139
R409, R410	16-¼CN222J	Carbon res 2K2 ±5% ¼W	R903	16-¼CN100J	Carbon res 10 ±5% ¼W	Q611, Q612	30-2125	Transistor 2N6551
R411, R412	16-¼CM162J	Carbon res 1K6 ±5% ¼W	R904	16-¼CN270J	Carbon res 27 ±5% ¼W	Q613, Q614	30-2126	Transistor 2N6554
R413, R414	16-¼CM105J	Carbon res 1M ±5% ¼W	R905-R911	16-¼CM122J	Carbon res 1K2 ±5% ¼W	Q615, Q616	30-2004R	Transistor 2N3055
R415, R416	16-¼CN391J	Carbon res 390 ±5% ¼W	R912	16-¼CN101J	Carbon res 100 ±5% ¼W	Q617, Q618	30-2114R	Transistor 2N2955
R417, R418	16-¼CN820J	Carbon res 82 ±5% ¼W	R913, R914	16-¼CM153J	Carbon res 15K ±5% ¼W	Q901	30-2083	Transistor BD139
R419, R420	16-¼CM823J	Carbon res 82K ±5% ¼W	R915	16-¼CM104J	Carbon res 100K ±5% ¼W	Q902	30-2082	Transistor BD140
R421, R422	16-¼CN181J	Carbon res 180 ±5% ¼W	C401, C402	17-2.5E475Y	Elec. Capa. 4.7μ F/25V ±75-10%	Q903	30-2084-3	Transistor BC549C
R423, R424	16-¼CM563J	Carbon res 56K ±5% ¼W	C403, C404	17-5D470M	Cer. Capa. 47P ±20%	Q904	30-2085-2	Transistor BC559B
R425, R426	16-¼CM224J	Carbon res 220K ±5% ¼W	C407, C408	17-5F102J	Mylar Capa. 0.0015μ F 50V ±5%	D1-D6	30-1048	LED RED
R427, R428	16-¼CM471J	Carbon res 470 ±5% ¼W	C409, C410	17-0.63E476Y	Elec. Capa. 47μ F/6.3V +50-10%	D401-D408	30-1019	Diode BAW62
R501, R502	16-¼CM181J	Carbon res 180 ±5% ¼W	C411, C412	17-5F152J	Mylar Capa. 0.0015μ F 50V ±5%	D601-D606	30-1019	Diode BAW62
R503, R504	16-¼CU562J	Carbon res 5K6 ±5% ¼W	C413, C414	17-5D100M	Cer. Capa. 10P ±20%	D701-D704	30-1019	Diode BAW62
R505, R506	16-¼CU224J	Carbon res 220K ±5% ¼W	C415, C416	17-5F102J	Mylar Capa. 0.001μ F 50V ±5%	D801, D802	30-1010	Diode IN60
R507, R508	16-¼CU104J	Carbon res 100K ±5% ¼W	C417, C418	17-2.5E475Y	Elec. Capa. 4.7μ F/25V ±75-10%	D803	30-1002	Diode IN4002
R509, R510	16-¼CM272J	Carbon res 2K7 ±5% ¼W	C419, C420	17-5D104M	Cer. Capa. 0.1μ F ±20%	D901-D904	30-1002	Diode IN4002
R511, R512	16-¼CM224J	Carbon res 220K ±5% ¼W	C421	17-5D473M	Cer. Capa. 0.047μ F ±20%	BD901	30-1049	Bridge Diode KBL02
R513, R514	16-¼CM104J	Carbon res 100K ±5% ¼W	C422, C423	17-5F102J	Mylar Capa. 0.001μ F 50V ±5%	BD901	30-1016	Zenerdiode 23V
R515, R516	16-¼CM391J	Carbon res 390 ±5% ¼W	C501, C502	17-5F122J	Mylar Capa. 0.0012μ F 50V ±5%	VR1	29-4081A	Volume 20KB (Vol)x2 40% TAP
R517, R518	16-¼CM822J	Carbon res 8K2 ±5% ¼W	C503, C504	17-5F224J	Mylar Capa. 0.22μ F 50V ±5%	VR2, VR3	29-4075A	Treble & Bass 10KCx2
R519, R520	16-¼CM392J	Carbon res 3K9 ±5% ¼W	C505-C508	17-5F104J	Mylar Capa. 0.1μ F 50V ±5%	VR4	29-4076A	Balance 20KWx1
R521, R522	16-¼CM123J	Carbon res 12K ±5% ¼W	C509, C510	17-5D101M	Cer. Capa. 100P ±20%	VR5, VR6	29-4023	Semifixed Res 20K
R523, R524	16-¼CN561J	Carbon res 560 ±5% ¼W	C511, C512	17-5D100M	Cer. Capa. 10P ±20%	VR7	29-4083	Semifixed Res 10K
R525, R526	16-¼CM562J	Carbon res 5K6 ±5% ¼W	C513-C518	17-0.63E476Y	Elec. Capa. 47μ F/6.3V +50-10%	SW1-SW4	31-1071T	Push SW 2U 4Key
R527, R528	16-¼CN101J	Carbon res 100 ±5% ¼W	C519, C520	17-5F183J	Mylar Capa. 0.018μ F 50V ±5%	SW5-SW6	31-1074T	Push SW 2U 2Key
R529, R530	16-¼CM102J	Carbon res 1K ±5% ¼W	C521, C522	17-5F104J	Mylar Capa. 0.1μ F 50V ±5%	SWT	31-1087	SLIDE SWITCH
R531, R532	16-¼CM181J	Carbon res 180 ±5% ¼W	C523, C524	17-0.63E476Y	Elec. Capa. 47μ F/6.3V +50-10%	IC1	30-3038	LB1405
R533, R534	16-¼CM683J	Carbon res 68K ±5% ¼W	C525, C526	17-5F124J	Mylar Capa. 0.12μ F 50V ±5%	L601, L602	29-1040	Inductor 1μ H
R537, R538	16-¼CM332J	Carbon res 3K3 ±5% ¼W	C527, C528	17-1.0684J	TA Capa. 0.68μ F/16V ±5%	TB1, TB2	35-3011	Breaker A-22
R539, R540	16-¼CM561J	Carbon res 560 ±5% ¼W	C601-C604	17-1.0105K	TA Capa. 1μ F/16V ±10%			
R541, R542	16-¼CM123J	Carbon res 12K ±5% ¼W	C605, C606	17-0.63E476Y	Elec. Capa. 47μ F/6.3V +50-10%			
R543, R544	16-¼CM152J	Carbon res 1K5 ±5% ¼W	C609, C610	17-5F332J	Mylar Capa. 0.0033μ F 50V ±5%			
R601, R602	16-¼CM224J	Carbon res 220K ±5% ¼W	C611, C614	17-5F102J	Mylar Capa. 0.001μ F 50V ±5%			
R603, R604	16-¼CM5625	Carbon res 5K6 ±5% ¼W	C615, C616	17-0.63E108Y	Elec. Capa. 1000μ F/6.3V +50-10%			
R605, R606	16-¼CM223J	Carbon res 22K ±5% ¼W	C617, C618	17-5D470M	Cer. Capa. 47P ±20%			
R607, R608	16-¼CM391J	Carbon res 390 ±5% ¼W	C619-C622	17-5D221M	Cer. Capa. 220P ±20%			
R609, R610	16-¼CM223J	Carbon res 22K ±5% ¼W	C623, C624	17-5D220M	Cer. Capa. 22P ±20%			
R611, R612	16-¼CM122J	Carbon res 1K2 ±5% ¼W	C625, C626	17-2.5E476Y	Elec. Capa. 47μ F/25V +50-10%			
R613, R614	16-¼CN561J	Carbon res 560 ±5% ¼W	C627, C628	17-5F104J	Mylar Capa. 0.1μ F 50V ±5%			
R617-R620	16-¼CM222J	Carbon res 2K2 ±5% ¼W	C631, C632	17-5F1022J	Mylar Capa. 0.001μ F 50V ±5%			
R621, R622	16-¼CM183J	Carbon res 18K ±5% ¼W	C633, C634	17-5F104J	Mylar Capa. 0.1μ F 50V ±5%			
R623, R624	16-¼CN391J	Carbon res 390 ±5% ¼W	C635-C638	17-5D104M	Cer. Capa. 0.1μ F ±20%			
R625, R626	16-¼CM224J	Carbon res 220K ±5% ¼W	C639, C640	17-5F104J	Mylar Capa. 0.1μ F 50V ±5%			
R627, R628	16-¼CM122J	Carbon res 1K2 ±5% ¼W	C641, C642	17-5D101M	Cer. Capa. 100P ±20%			
R629, R630	16-¼CN391J	Carbon res 390 ±5% ¼W	C701, C702	17-0.63E476Y	Elec. Capa. 47μ F/6.3V +50-10%			
R631, R632	16-¼CM270J	Carbon res 27 ±5% ¼W	C703-C706	17-2.5E476Y	Elec. Capa. 47μ F/25V +50-10%			
R633, R634	16-¼CM101J	Carbon res 100 ±5% ¼W	C801	17-2.5E475Y	Elec. Capa. 47μ F/25V ±75-10%			
R635, R636	16-½CM222J	Carbon res 2K2 ±5% ½W	C802	17-1.6E475Y	Elec. Capa. 47μ F/16V ±75-10%			
R637, R638	16-½CN122J	Carbon res 1K2 ±5% ¼W	C805	17-5D500M	Cer. Capa. 50P ±20%			
R639, R640	16-¼CM391J	Carbon res 390 ±5% ¼W	C806	17-1.6E105Y	Elec. Capa. 1μ F/16V ±75-10%			
R641, R642		Carbon res RX ±5% ¼W	C807	17-1.6E227Y	Elec. Capa. 220μ F/16V +50-10%			
R643, R644	16-¼CN680J	Carbon res 68 ±5% ¼W	C901, C902	17-3.5E228Y	Elec. Capa. 2200μ F/35V +50-10%			
R645, R646	16-¼CM391J	Carbon res 390 ±5% ¼W	C903, C904	17-5D473M	Cer. Capa. 0.047μ F ±20%			
R647, R648	16-¼CM122J	Carbon res 1K2 ±5% ¼W	C905, C906	17-3.5E477Y	Elec. Capa. 470μ F/35V +50-10%			
R649, R650	16-¼CN122J	Carbon res 1K2 ±5% ½W	C907, C908	17-3.5E476Y	Elec. Capa. 47μ F/35V +50-10%			
R651, R652	16-¼CN181J	Carbon res 180 ±5% ¼W	C909, C910	17-5D220M	Cer. Capa. 22P ±20%			
R653, R656	16-2BR22K	Cement res 0.22 ±10% 2W	C911	17-3.5E476Y	Elec. Capa. 47μ F/35V +50-10%			
R657, R658	16-1A100K	Metal Oxide res 10 ±10% 1W	C912, C913	17-3.5E475Y	Elec. Capa. 4.7μ F/35V ±75-10%			
R659, R660	16-½CM221J	Carbon res 220 ±5% ½W	C914	17-3.5E476Y	Elec. Capa. 47μ F/35V +50-10%			
R661, R662	16-½CN471J	Carbon res 470 ±5% ½W	C915, C916	17-3.5E228Y	Elec. Capa. 2200μ F/35V +50-10%			
R701-R704	16-¼CM224J	Carbon res 220K ±5% ¼W	Q401, Q402	30-2085-2	Transistor BC559B			
R705, R706	16-¼CM123J	Carbon res 12K ±5% ¼W	Q403, Q404	30-2084-3	Transistor BC549C			
R707-R710	16-¼CM471J	Carbon res 370 ±5% ¼W	Q405, Q406	30-2085-2	Transistor BC559B			
R711, R712	16-¼CM123J	Carbon res 12K ±5% ¼W	Q407, Q408	30-2096	Transistor BC556			
R801, R802	16-¼CN222J	Carbon res 2K2 ±5% ¼W	Q409, Q410	30-2090	Transistor BC546			
R803, R804	16-¼CN471J	Carbon res 370 ±5% ¼W	Q501, Q502	30-2085-2	Transistor BC559B			
R805	16-¼CM104J	Carbon res 100K ±5% ¼W	Q503, Q504	30-2124	Transistor 2SC1400			
R813	16-¼CU183J	Carbon res 18K ±5% ¼W	Q505, Q506	30-2090	Transistor BC546			